

Section 1. PRODUCT DESCRIPTION

FRAME PLUG WITH HEX/COUNTERSUNK HEAD SCREW AND TX DRIVE – KPR-FAST 10 K/KPS-FAST 10 S

Sleeves of frame plugs are made of polyamide with a specially shaped steel screw type K (hex head) or S (countersunk head) for fixing of members to all substrate types. The screws are made of steel with applied electroplated zinc coating or with non-electrolytically applied zinc flake coating. The plastic sleeve is expanded by screwing in the specific screw which presses the sleeve against the wall of the drilled hole. Frame plugs are characterized by very high resistance and problem-free installation in various materials. Plugs with hex head (K) are mostly used for fixing of metal members, and plugs with countersunk head (S) mostly for fixing of wood members. The sleeve is pre-assembled with the screw.

Substrates on which frame plug KPR-FAST 10 K/KPS-FAST 10 S can be installed according to ETAG 020:

- Category A – concrete
- Category B – solid clay brick and sand-lime brick
- Category C – hollow clay and sand-lime brick, porous block
- Category D – lightweight concrete blocks, autoclaved aerated concrete

Frame plugs hold European Technical Assessment: ETA-12/0272



THE DIAMETER OF THE SCREW'S CORE IS REDUCED



KPS-FAST 10 S

KPR-FAST 10 K



Section 2. METHOD OF INSTALLATION

1. Original frame plugs delivered by the manufacturer can be used only
2. Before installation identify a substrate into which the plug will be installed and compare loads which the plug will carry to resistance values given in Product Data Sheet or European Technical Assessment
3. Select an adequate length of the plug so that expansion zone is in the construction material of the wall (thickness of member being fixed matches max. usable length of the plug – t_{fix})
4. Use proper method of drilling according to a substrate type (holes in brickwork substrate made of hollow or autoclaved aerated concrete blocks should be drilled using a drill without impact)
5. Diameter of drilled holes should match diameter of the plugs used
6. Drilled holes in substrates of solid materials should be deeper by min. 10mm compared to the plug anchorage depth
7. Clean the holes in solid materials from drilling dust and debris with a back and forth motion of the drill at a reduced speed
8. Then insert the plug into a drilled hole, and drive the screw until it completely penetrates the sleeve
9. Forceful tightening of the screw can result in its failure which is not covered by the manufacturer's warranty
10. Installation shall be executed in temperature from -20°C to $+40^{\circ}\text{C}$. (this applies to substrate temperature)

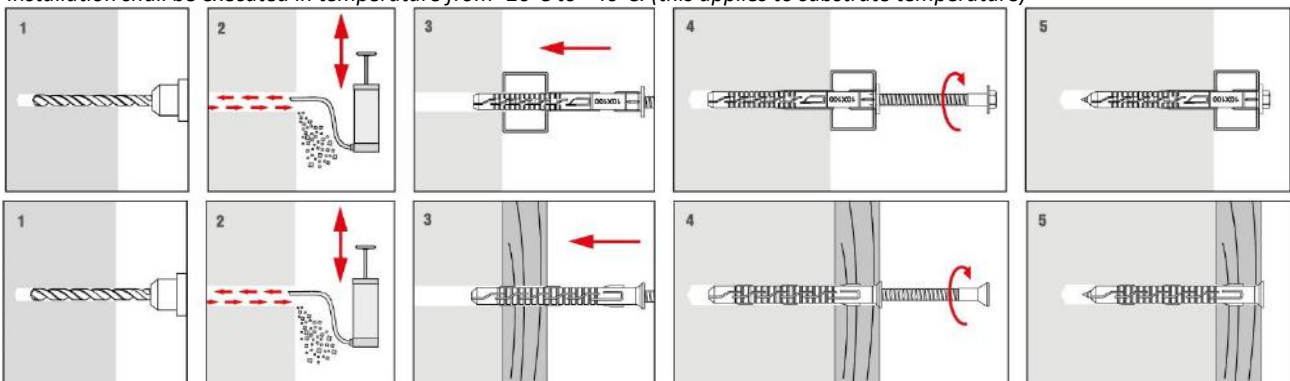

PRODUCT DATA SHEET – KPR-FAST 10 K/KPS-FAST 10 S

Section 3. TECHNICAL DATA

TECHNICAL PARAMETERS		
Parameter	Unit	Value
Plug diameter	d_k [mm]	10
Hole/drill diameter	d_o [mm]	10
Effective anchorage depth	h_{eff} [mm]	50/70
Drilled hole depth	h_o [mm]	60/80
Drive type	[-]	(TX-40/SW-13)/(TX-40)*
Use categories	[-]	A B C D
Sleeve material	[-]	PA – polyamide
Screw material	[-]	Steel with applied electroplated zinc coating or with non-electrolytically applied zinc flake coating
European Technical Assessment	[-]	ETA-12/0272

*for KPR-FAST 10 K/KPS-FAST 10 S

**cracked concrete

¹⁾ According to EN 771-1

²⁾ According to EN 771-2

³⁾ According to EN 771-3

⁴⁾ According to EN 771-4

⁵⁾ Polish clay brick; (L x W x H) = 250 x 120 x 65 mm

⁶⁾ German clay brick MZ Rd 2.0/20; (L x W x H) = 250 x 120 x 65 mm

⁷⁾ For example Kalksandstein KS NF 20-2.0 Vollstein according to DIN 106; (L x W x H) = 250 x 115 x 71 mm

⁸⁾ For example Porotherm 18.8; (L x W x H) = 468 x 188 x 238 mm

⁹⁾ For example Porotherm 25 P+W; (L x W x H) = 250 x 373 x 238 mm

¹⁰⁾ For example MAX 250; (L x W x H) = 250 x 373 x 238 mm

¹¹⁾ For example HLZ Rd1 1.2/12 according to DIN 105; (L x W x H) = 308 x 240 x 238 mm

¹²⁾ For example KSL-R(P)8DF Lochstein according to DIN 106; (L x W x H) = 498 x 115 x 245 mm

¹³⁾ For example Hbl 2/0.8 Leichtbetonhohlstein according to DINV 18 151-100; (L x W x H) = 365 x 247 x 238 mm

¹⁴⁾ For example TeknoAmerBlok PK17,8; (L x W x H) = 178 x 390 x 190 mm

¹⁵⁾ For example TeknoAmerBlok PK19; (L x W x H) = 190 x 390 x 190 mm

RESISTANCE					
Use categories	Substrate type	Density [kg/dm ³]	Compressive strength [N/mm ²]	Characteristic resistance [kN/pcs]	
				$h_{eff}=50$ mm	$h_{eff}=70$ mm
A	Concrete C12/15	≥ 2,25	$f_{c,cyl} ≥ 12$	3,0**	6,0**
A	Concrete ≥ C16/20	≥ 2,30	$f_{c,cyl} ≥ 16$	4,0**	8,5**
A	Thin-wall concrete elements C16/20, h ≥ 30mm	≥ 2,30	$f_{c,cyl} ≥ 16$	4,0**	4,0**
B	Clay brick ^{1),5)}	≥ 1,70	≥ 10	1,5	2,0
B	Clay brick ^{1),5)}	≥ 1,70	≥ 20	2,0	3,5
B	Clay brick ^{1),6)}	≥ 2,00	≥ 10	2,0	2,0
B	Clay brick ^{1),6)}	≥ 2,00	≥ 20	3,0	3,0
B	Calcium silicate brick ^{2),7)}	≥ 2,00	≥ 20	3,0	3,0
C	Perforated ceramic brick ^{1),8)}	≥ 0,80	≥ 15	1,2	1,0
C	Perforated ceramic brick ^{1),9)}	≥ 0,80	≥ 15	2,5	1,0
C	Perforated ceramic brick ^{1),10)}	≥ 0,80	≥ 15	2,5	1,0
C	Perforated ceramic brick ^{1),11)}	≥ 1,20	≥ 12	1,5	1,5
C	Calcium silicate hollow block ^{2),12)}	≥ 1,60	≥ 12	2,5	2,5
C	Aggregate concrete masonry units ^{3), 14)}	≥ 0,80	≥ 2	1,5	1,5
C	Aggregate concrete masonry units ^{3), 15)}	≥ 1,5	≥ 25	3,5	3,5
D	Lightweight concrete blocks (LAC) ³⁾	≥ 1,0	≥ 20	4,0	4,0
D	Autoclaved aerated concrete AAC 2 ⁴⁾	≥ 0,35	≥ 2	-	0,9
D	Autoclaved aerated concrete AAC 7 ⁴⁾	≥ 0,65	≥ 6,5	-	2,0

PRODUCT DATA SHEET – KPR-FAST 10 K/KPS-FAST 10 S

MINIMUM THICKNESS OF MEMBER, EDGE DISTANCE AND SPACING IN CONCRETE						
ANCHOR TYPE	Base material	Minimum thickness of member	Characteristic edge distance	Characteristic spacing	Minimum edge distance	Minimum spacing
		h_{min} [mm]	$C_{cr,N}$ [mm]	$S_{cr,N}$ [mm]	C_{min} [mm]	S_{min} [mm]
KPR-FAST 10/50* KPS-FAST 10/50*	Concrete \geq C16/20	100	100	75	50 for $s \geq 150$ mm	50 for $c \geq 100$ mm
	Concrete \geq C12/15	100	140	105	70 for $s \geq 210$ mm	70 for $c \geq 140$ mm
	Thin wall concrete elements \geq C16/20	30	100	100	100	100
KPR-FAST 10/70** KPS-FAST 10/70**	Concrete \geq C16/20	100	100	110	50 for $s \geq 150$ mm	50 for $c \geq 100$ mm
	Concrete \geq C12/15	100	140	150	70 for $s \geq 210$ mm	70 for $c \geq 150$ mm
	Thin wall concrete elements \geq C16/20	30	100	100	100	100

* $h_{eff}=50$ mm / ** $h_{eff}=70$ mm

Scheme of edge distance and spacing in concrete

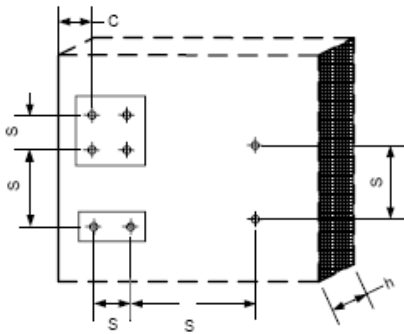

Scheme of edge distance and spacing in thin-wall concrete elements

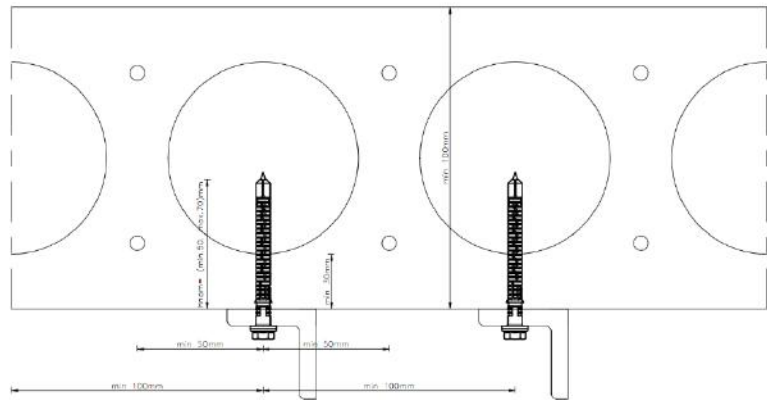

MINIMUM THICKNESS OF MEMBER, EDGE DISTANCE AND SPACING IN MASONRY								
ANCHOR DIAMETER	Podłoże	Type of element	Single anchor			Anchor group ¹⁾		
			Minimum thickness of member	Minimum edge distance	Minimum spacing	Minimum spacing	Minimum spacing	
			h_{min} [mm]	C_{min} [mm]	S_{min} [mm]	S_{min1} ²⁾ [mm]	S_{min2} ³⁾ [mm]	
$\Phi 10$	masonry made of ceramic, calcium silicate and lightweight aggregate concrete elements	solid	120	100	100	100	200	
		perforated or hollow	180	100	100	100	200	
	masonry made of autoclaved aerated concrete elements	-	100	100	100	100	200	

¹⁾ the design method valid for single anchor and anchor groups with two or four anchors

²⁾ in direction perpendicular to free edge

³⁾ in direction parallel to free edge

PRODUCT DATA SHEET – KPR-FAST 10 K/KPS-FAST 10 S

Scheme of edge distance and spacing in masonry

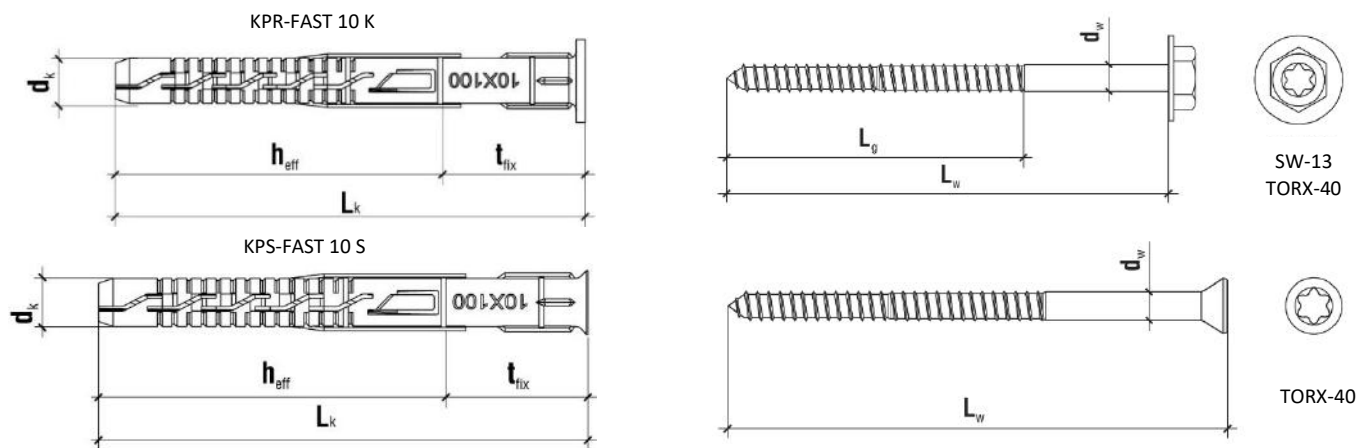
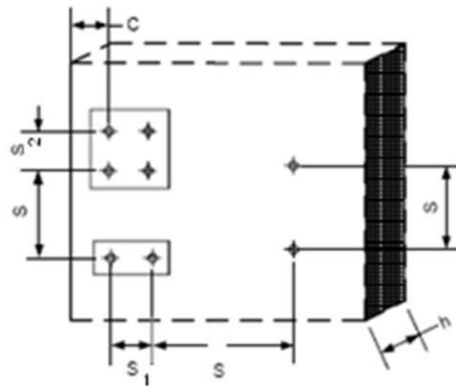

SELECTION TABLE – KPR-FAST 10 K					
Product code	Sleeve diameter and length	Screw diameter and length	Max. usable length	Drive type	Number of pieces in a box
<i>Steel with applied electroplated zinc coating or with non-electrolytically applied zinc flake coating</i>	$d_k \times L_k$ [mm]	$d_w \times L_w$ [mm]	t_{fix} [mm]	[-]	[szt.]
KPR-FAST-10060K	10x60	7x65	10	TX-40/SW-13	50
KPR-FAST-10080K	10x80	7x85	10/30*	TX-40/SW-13	50
KPR-FAST-10100K	10x100	7x105	30/50*	TX-40/SW-13	50
KPR-FAST-10120K	10x120	7x125	50/70*	TX-40/SW-13	50
KPR-FAST-10140K	10x140	7x145	70/90*	TX-40/SW-13	50
KPR-FAST-10160K	10x160	7x165	90/110*	TX-40/SW-13	50
KPR-FAST-10180K	10x180	7x185	110/130*	TX-40/SW-13	25
KPR-FAST-10200K	10x200	7x205	130/150*	TX-40/SW-13	25
KPR-FAST-10230K	10x230	7x235	160/180*	TX-40/SW-13	25
KPR-FAST-10260K	10x260	7x265	190/210*	TX-40/SW-13	25
KPR-FAST-10300K	10x300	7x305	230/250*	TX-40/SW-13	25

*for $h_{eff}=70$ mm/ $h_{eff}=50$ mm

PRODUCT DATA SHEET – KPS-FAST 10 K/KPS-FAST 10 S

SELECTION TABLE – KPS-FAST 10 S					
Product code	Sleeve diameter and length	Screw diameter and length	Max. usable length	Drive type	Number of pieces in a box
<i>Steel with applied electroplated zinc coating or with non-electrolytically applied zinc flake coating</i>	$d_k \times L_k$ [mm]	$d_w \times L_w$ [mm]	t_{fix} [mm]	[-]	[szt.]
KPS-FAST-10060S	10x60	7x65	10	TX-40	50
KPS-FAST-10080S	10x80	7x85	10/30*	TX-40	50
KPS-FAST-10100S	10x100	7x105	30/50*	TX-40	50
KPS-FAST-10120S	10x120	7x125	50/70*	TX-40	50
KPS-FAST-10140S	10x140	7x145	70/90*	TX-40	50
KPS-FAST-10160S	10x160	7x165	90/110*	TX-40	50
KPS-FAST-10180S	10x180	7x185	110/130*	TX-40	25
KPS-FAST-10200S	10x200	7x205	130/150*	TX-40	25
KPS-FAST-10230S	10x230	7x235	160/180*	TX-40	25
KPS-FAST-10260S	10x260	7x265	190/210*	TX-40	25
KPS-FAST-10300S	10x300	7x305	230/250*	TX-40	25

*for $h_{eff}=50$ mm/ $h_{eff}=70$ mm



Section 4. REMARKS

1. All previous versions of this Product Data Sheet shall cease to be valid
2. Data given in this Product Data Sheet is in accordance with current knowledge and published in good faith. KLIMAS Sp. z o.o. is not responsible for correctness and quality of the fixing if recommendations regarding method of use and installation are not followed.